



www.santos.fr

ICE CRUSHER # 09
For crushed and snow ice

**New
design**



Internationally patented model





NEW ICE CRUSHER

New ice crusher, powerful and sturdy, delivered with an adjustable disc to make snow ice or crushed ice. Ideal for bars, restaurants, fish shops, caterers... Its new design facilitates cleaning and maintenance.

Safety switch stopping the motor when the lever or the drawer is opened

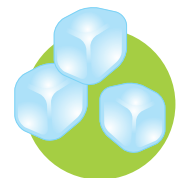
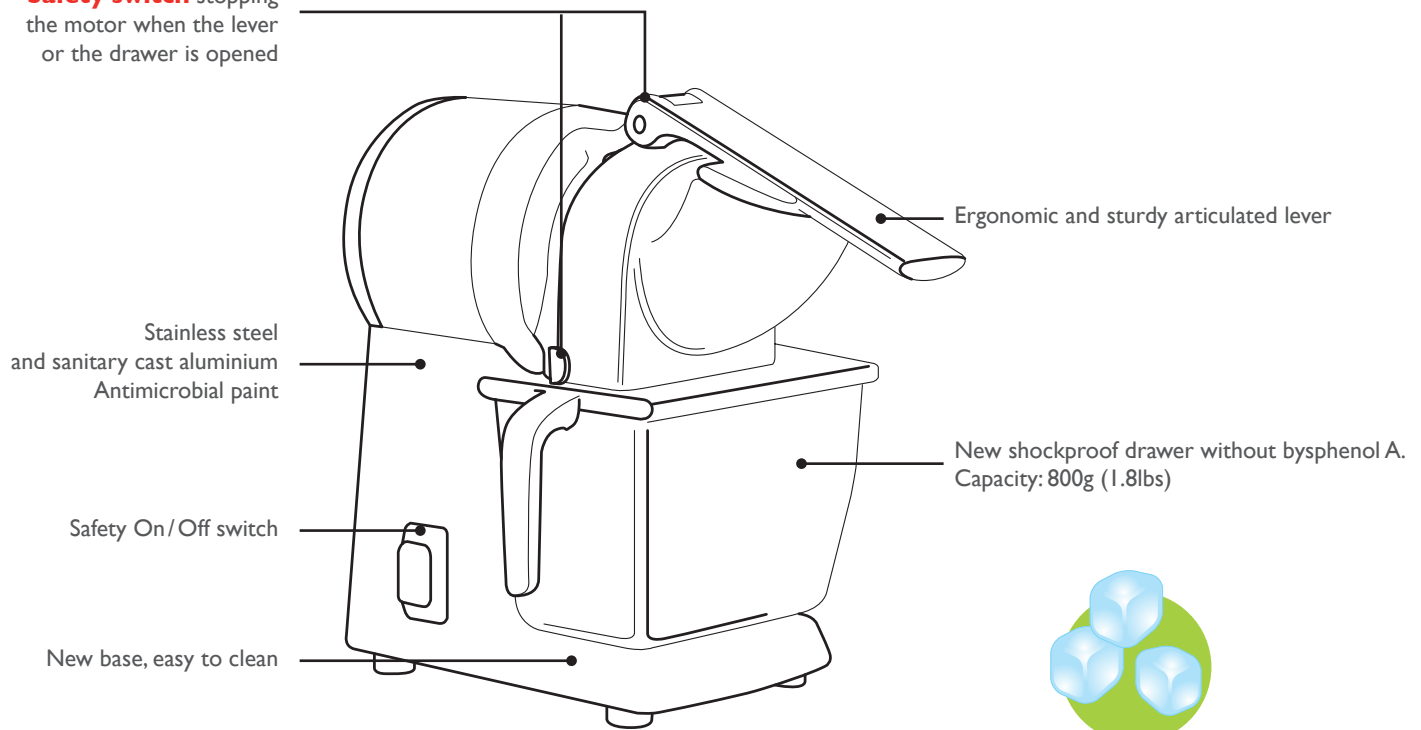

100 Kg / Hour
(220lbs / hour)

NEW APPLICATIONS

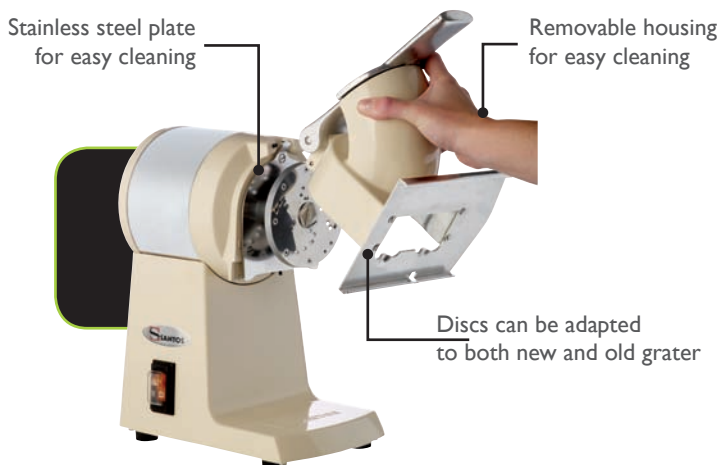

ICE CRUSHER # 09



ONE DISC = TWO POSSIBILITIES

www.santos.fr

The ice crusher # 09 is delivered with one adjustable disc which can make snow ice and crushed ice.



Disc adjusted in "snow ice" position



Disc adjusted in "crushed ice" position



Option: All the discs for the Grater # 02 are adaptable to the ice Crusher # 09

TECHNICAL SPECIFICATIONS



Motor

Single phase: 220-240V – 50/60 Hz – 600W – EC
100-120V – 50/60 Hz – 650W – EC, UL

Speed: | 500 rpm (50Hz)
| 800 rpm (60 Hz)



Weight

Net: 14,5 Kg (32 lbs)
Shipping: 15,5 Kg (34 lbs)

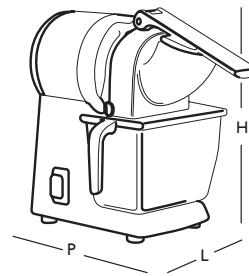

APPLIANCE

L : 250 mm / 10"
P : 420 mm / 16,5"
H : 360 mm / 14"

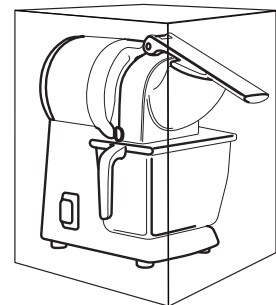

SHIPPING BOX

L : 295 mm / 12"
P : 455 mm / 21"
H : 410 mm / 16"

SAFETY, STANDARD, HYGIENE

In accordance with the following regulations

Machinery directive 2006/42/EC
Electromagnetic compatibility 2004/108/EC
"Low voltage" directive 2006/95/EC
Regulation 1935/2004/EC (contact with food)
RoHS directive 2002/95/EC

Harmonized European Standards
NF EN ISO 12100 - 1 & 2: 2004
NF EN 60204-1: 2006

CE (European standards), UL (USA) and cUL (Canada)

Thermal Safety

Motor protected by internal thermal detector.

Acoustic Safety

Very silent and powerful asynchronous motor.

Hygiene

All removable parts can be put in a dishwasher or easily cleaned with hot soapy water.

PRODUCT: 2-YEAR WARRANTY | MOTOR: 5-YEAR WARRANTY

ICE CRUSHER #09



www.santos.fr

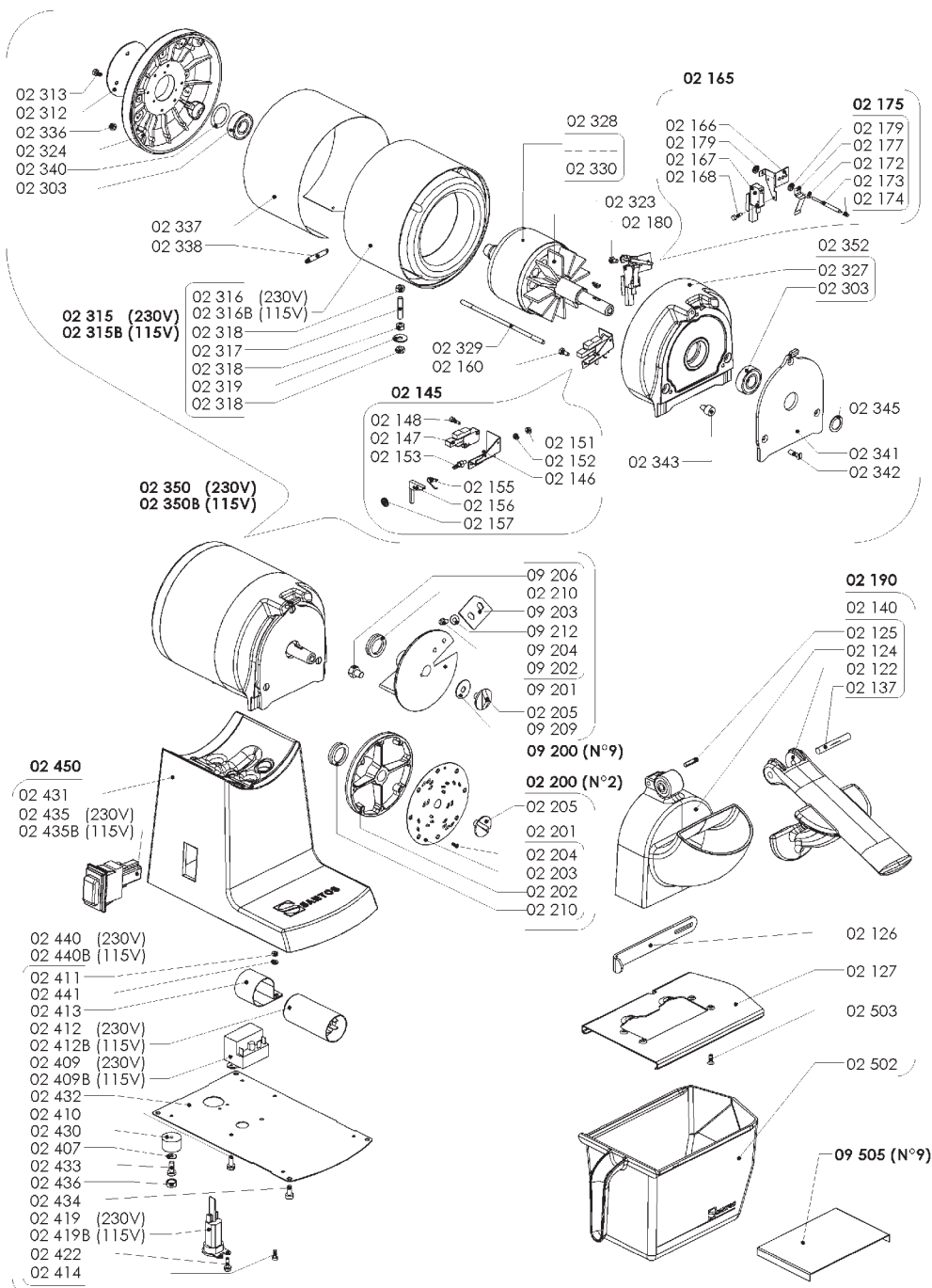

140-150 AV ROGER SALENGRO – 69120 – VAULX EN VELIN – LYON – FRANCE – TEL. +33 472 37 35 29 – FAX. +33 478 26 58 21
Website: www.santos.fr – **E-mail:** santos@santos.fr