



www.santos.fr

BRUSHLESS BLENDER # 62
Green Technology and high performance



Silence

Perfect blend

Brushless motor

**NEW
VERSION**

FOR JUICES BARS AND COFFEE SHOPS
World exclusive: BRUSHLESS MOTOR
SILENT, DURABLE, ECO-FRIENDLY

Internationally patented models





BLENDER FOR SMOOTHIES AND ICED DRINKS

You can make any kind of cocktails, smoothies, fruit juices, milkshakes, granitas, iced coffee frappe with the **Blender # 62**. Ideal appliance for juice bars, coffee shops, fast food, hotels...

The brushless Blender fits everywhere thanks to its sober design and its low overall dimensions. It can be used equally in its standard version or in-counter version to save space. Its new sound enclosure reduces the noise levels and the brushless motor is very quiet.

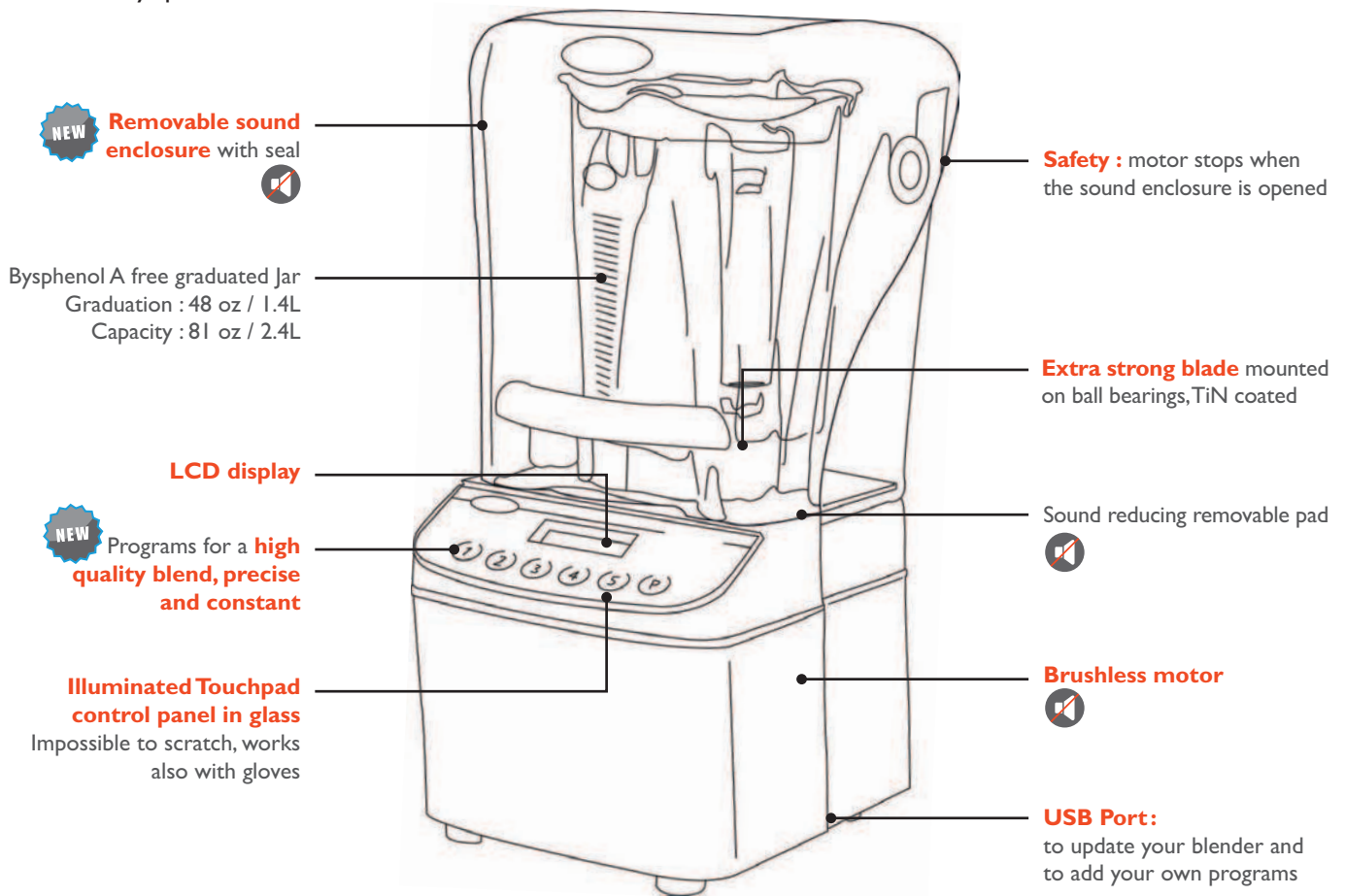

WHAT DOES BRUSHLESS MEAN ?

Unlike universal motors, brushless motor has no brushes (permanent magnet rotor) which gives it a **long lifetime** (no wearparts), an **excellent energy efficiency** and a **low noise level**.

Light years ahead in terms of sustainable development.



IN-COUNTER BLENDER

The **Brushless Blender # 62** can be used either in standard version or in-counter version (no additional option).

Easy to fit into a counter: simple and quick dismantling of the base.



Clip



NEW VERSION



PERFORMANCE, SILENCE, SIMPLICITY

www.santos.fr



PERFORMANCE

- **Brushless motor**: low consumption, high performance (8N.m).
- **TiN coated blade** : high resistance, adapted to intensive use.
- It crushes hard ice cubes and frozen fruits in a few seconds.
- **Obtain the perfect drink** thanks to the various pre-programmed recipes.



Create your own recipes on www.brushlessblender.com



SIMPLICITY

- **Ease of use**: Touchpad control panel with LCD display.
- **6 programmable buttons** 30 pre-programmed recipes + possibility to create its own recipes (free software + USB port)
- **Easy cleaning** : Removable sound enclosure, pad and jar.
- **Stackable jars, graduated in milliliters and ounces**, adapted to right-handers and left-handers.
- Easy to fit into a counter.
- **Easy maintenance**: each part of the jar can be dismantled (including the blade).



SILENCE

- Silent **brushless motor**.
- **New removable sound enclosure** reducing significantly the noise level.
- Sound reducing **pad**.

TECHNICAL SPECIFICATIONS



Moteur

Monophasé: 100-120V – 50/60Hz - CE
220-240V – 50/60Hz - CE
GS, KC

Couple Max: 8N.m



Poids

Net: 9,4Kg (21 lbs)
Emballé: 10,4Kg (23 lbs)

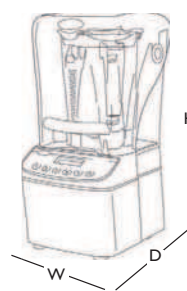

STANDARD APPLIANCE

W: 200,3 mm / 8"
D: 247 mm / 10"
H: 440,6 mm / 17"

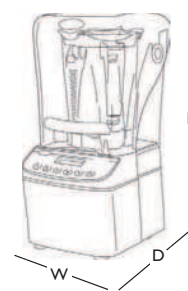

IN-COUNTERVERSION

W: 200,3 mm / 8"
D: 247 mm / 10"
H: 305,6 mm / 12"

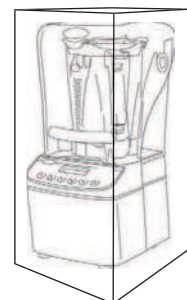

SHIPPING BOX

W: 260 mm / 10.2"
D: 290 mm / 11.4"
H: 500 mm / 18.9"

SAFETY, STANDARDS, HYGIENE

In accordance with the following regulations

Machinery directive 2006/42/EC
Electromagnetic compatibility 2004/108/EC
«low voltage» directive 2006/95/EC
RoHS directive 2002/95/EC

Harmonized European standards:

EN ISO12100-1 and 2: 2004 - EN 60204-1: 2006
EN 12852: 2001 Food processors and blenders – Safety and hygiene requirements

Electrical safety

Waterproof On/Off interlock switch
Appliances are 100% tested after assembly.

Thermal safety

Motor protected by internal thermal detector.

Acoustic safety

Very silent and powerful brushless motor.

Hygiene

All removable parts can be put in a dishwasher or easily cleaned with hot soapy water. Bysphenol-free.

PRODUCT : 2-YEAR WARRANTY

BLENDER BRUSHLESS N°62



www.santos.fr

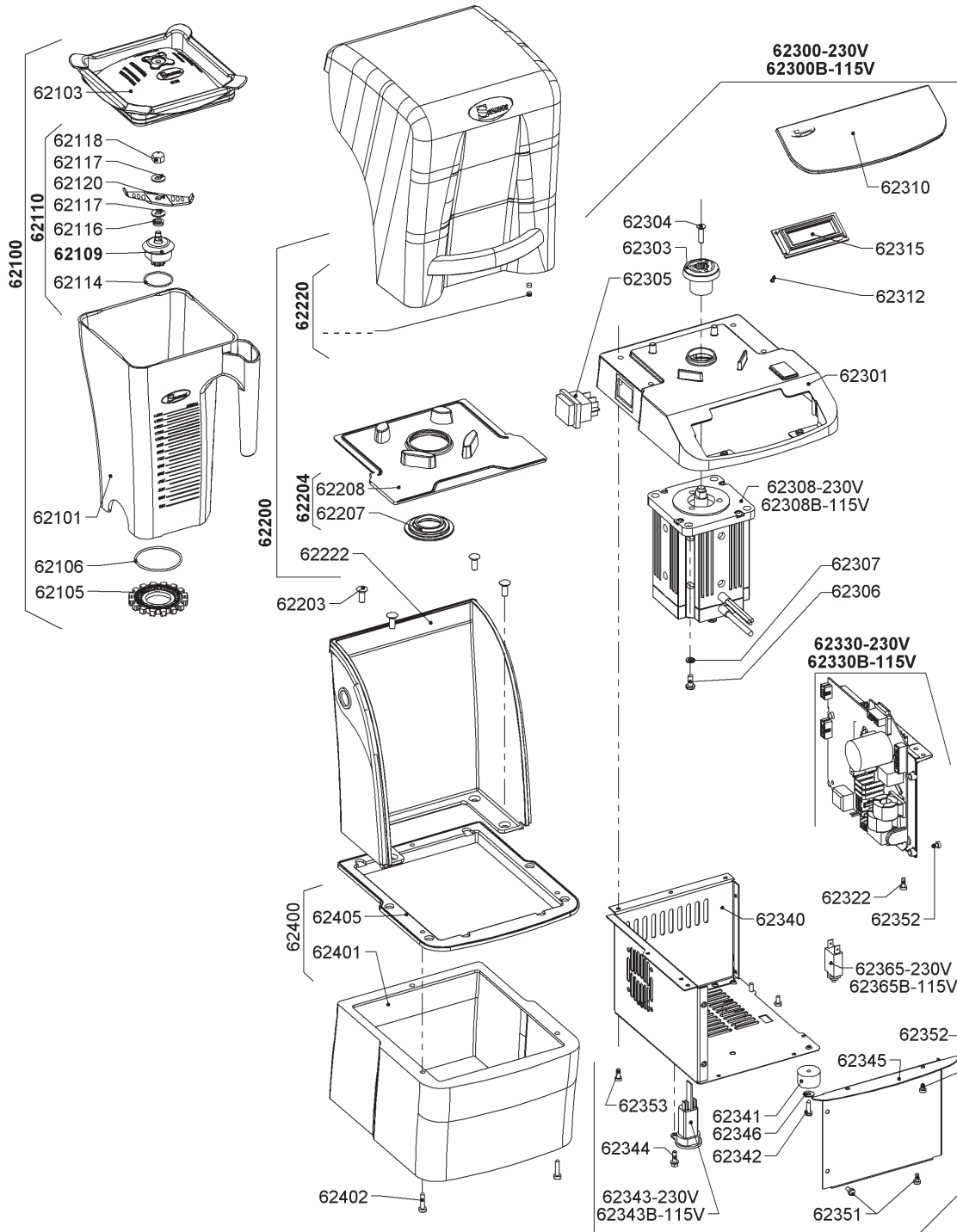

09/2013 - V6

SANTOS

140-150, avenue Roger Salengro - 69120 VAULX-EN-VELIN (Lyon) - FRANCE - Tel. +33 472 37 35 29 – Fax +33 478 26 58 21

Site Internet: www.santos.fr – E-mail: santos@santos.fr