

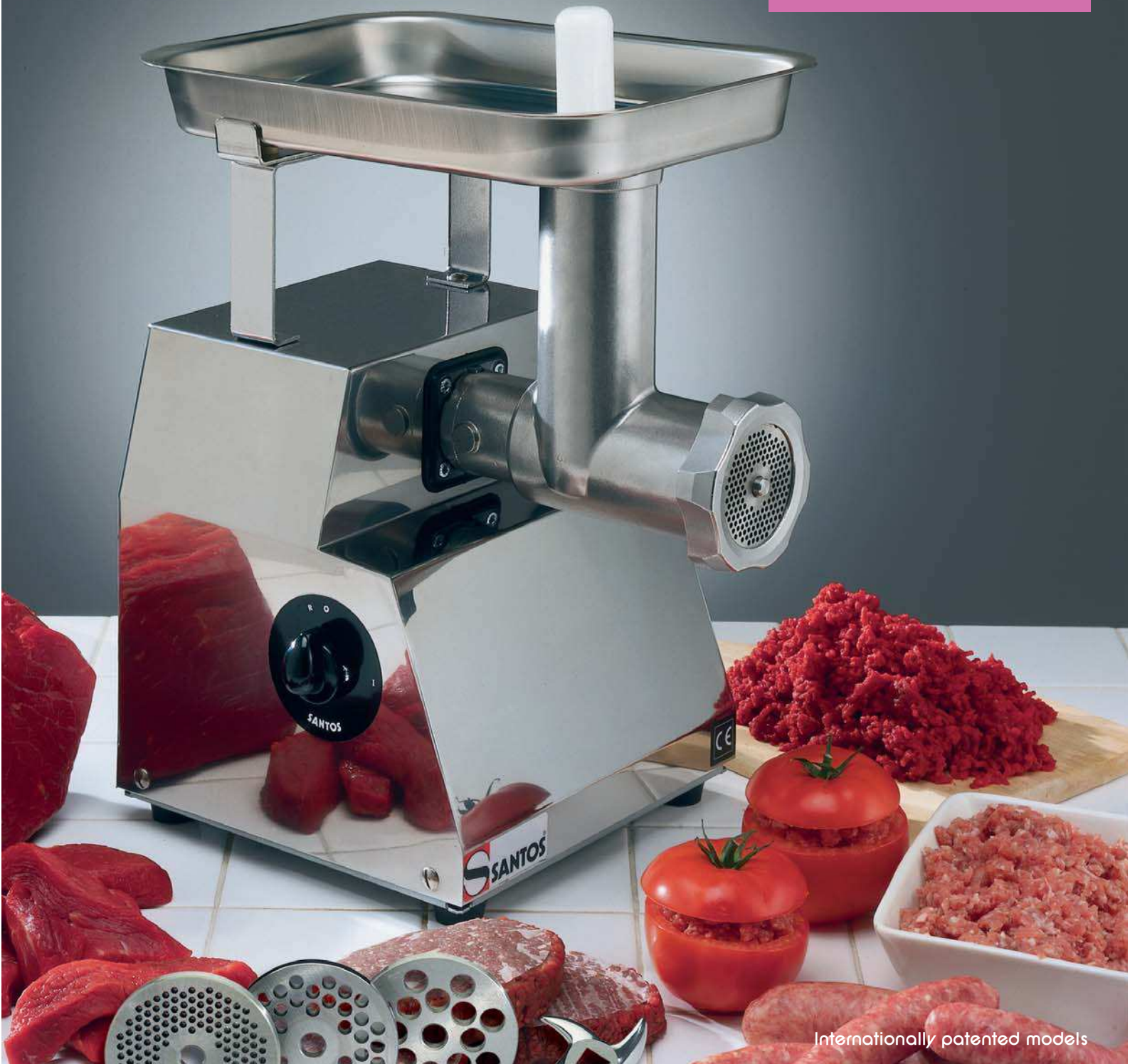

www.santos.fr

Economical, sturdy, ideal for small last minute preparations in kitchen and for French tartare

Meat Mincer #12
2 Models
n°12-8 : Ø 62 mm
n°12-12 : Ø 70 mm



Internationally patented models





Introducing the Santos meat mincer #12

- Dedicated to hotels, restaurants, institutions, butcher's shops, supermarkets...
- The ideal appliance for the preparation of ground beef, hamburger steak, sausages, pâtés...
- It can mince all kinds of meat, including the most difficult ones

Video



Stainless steel loading tray

Pusher

Quick release locking system

Stainless steel frame

2 mincer bodies are available:
- I2-12 : ø 70 mm stainless steel body
- I2-8 : ø 62 mm alimentary aluminium body

Enterprise system

Reliable Santos motor
Long lasting gear
(no greasing needed)

Reverse in case of jamming



Set of 3 sausages cones (in option) can be adapted with special plate with ø 20 mm holes

You can also choose it in red I2-12R



The appliance is delivered with 3 different mincing plates.



Meat Mincer #12

Easy to assemble, dismantle and to clean



www.santos.fr

All removable parts can be put in a dishwasher.

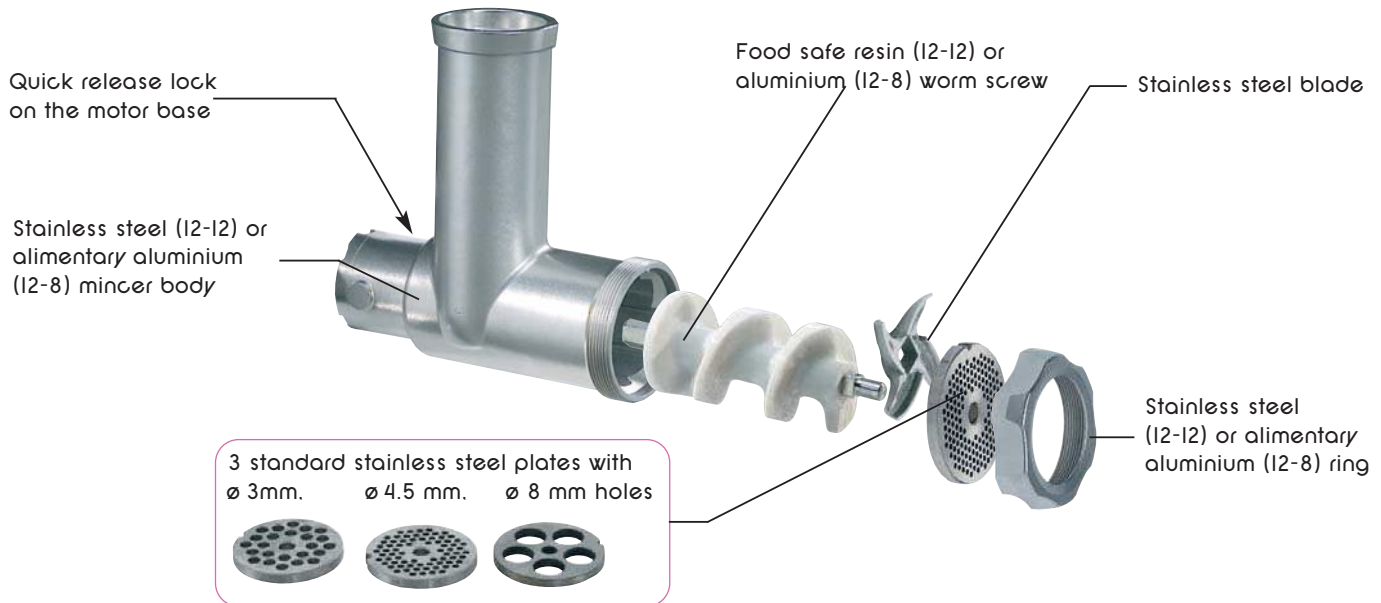

Technical data

Motor	• Single phase:	100-120V - 50/60 Hz - 650 W - CE 220-240V - 50/60 Hz - 600 W - CE
	• Speed:	1500 RPM. (50 Hz) 1800 RPM. (60 Hz)
	Blade rotation speed	140 RPM (50 Hz) 170 RPM (60 Hz)
Weight	• Output	
	• 12-8:	70 kg/h
	• 12-12:	160 kg/h
	• Net	12-8 17 Kg (37 lbs) 12-12 19 Kg (42 lbs)
	• Shipping	12-8 18 Kg (40 lbs) 12-12 21 Kg (46 lbs)

Appliance:

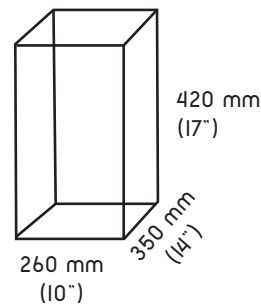

Shipping box:

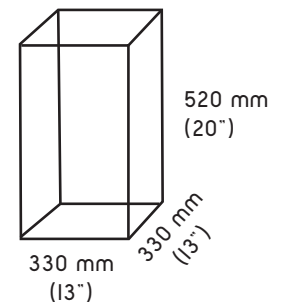

Safety - Standards - Hygiene

In accordance with the following regulations:

- ◆ Machinery directive 2006/42/EC
- ◆ Electromagnetic compatibility 2004/108/EC
- ◆ Electrical equipment designed for use within certain voltage limits "low voltage" 2006/95/EC
- ◆ Regulation 1935/2004/EC (contact with food)

Thermal safety

Appliance protected by overload protection.

Harmonized European standards

- ◆ EN ISO 12100-1 et 2: 2004 - EN 60204-1: 2006 - EN 12331-A2: 2010 meat mincer
- ◆ EN 60335-2-64 :2004 : Commercial electric kitchen machines
- ◆ CE (Europe)

Hygiene

All removable parts can be put in a dish washer or easily cleaned with hot soapy water.

PRODUCT: 2-YEAR WARRANTY - MOTOR: 5-YEAR WARRANTY

Meat Mincer #12

