



www.santos.fr

LEVER JUICER EVOLUTION #70

Ideal appliance to make fresh fruit juices (lemons, oranges, and grapefruits)



Internationally patented models





LEVER JUICER

SINCE 1954

The lever juicer evolution #70 is the ideal product to **make fresh juices** from lime, lemon, orange and grapefruit. Thanks to its powerful motor and its high output (50l/h) it is adapted to **intensive use**.

For use everywhere you need a fresh squeezed citrus juicer: juice bars, health food stores, hotels, bars, restaurants, cafeterias, ice cream shops, institutions, hospitals...

Efficient, practical and reliable:

- Allows you to make citrus juices either in a glass or in a jug
- Equipped with a **special squeezer for all types of citrus**: lime, lemon, orange or grapefruit
- **Automatic start** when we push the lever (patented clutch system)
- **Easy cleaning**: removable stainless steel bowl, cone and cup

 **Option:** Glass-raiser available on demand

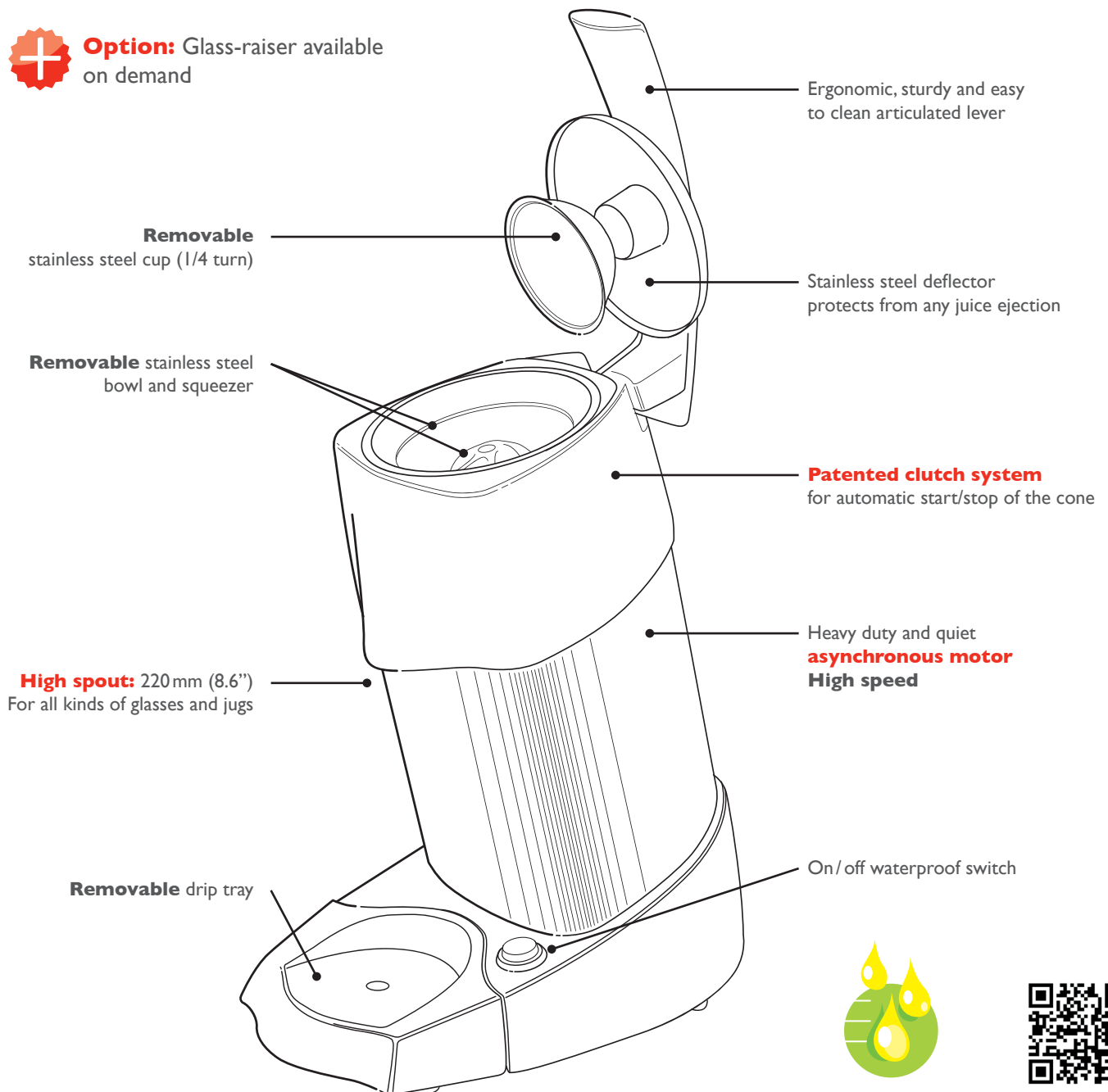

Output: 50l/h



VIDEO

EVOLUTION #70



THE PROFESSIONAL ART OF JUICING SINCE 1954

www.santos.fr

We have the citrus juicer you need, to make juice by glass or by jug.

Equipped with powerful and reliable commercial motors, they are the perfect appliances to quickly squeeze any kind of citrus, from small limes to big grapefruits. All of these juicers are very easy to clean: parts in contact with fruits are removable.



TECHNICAL SPECIFICATIONS



Motor

Single phase: 100 - 120V - 50/60 Hz – 350 W – NSF, UL, CE
220 - 240V - 50/60 Hz – 300 W – CE, GS, KC

Speed: 1 500 rpm (50 Hz)
1 800 rpm (60 Hz)



Weight

Net: 13.5 kg (30")
Shipping: 14.5 kg (32")

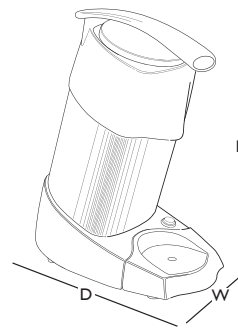

APPLIANCE
W: 240 mm (9")
D: 400 mm (16")
H: 490 mm (19,3")

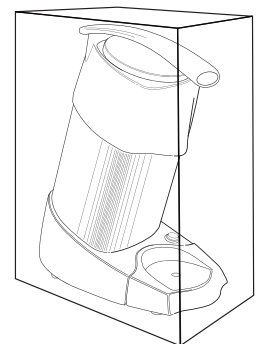

SHIPPING BOX
W: 280 mm (11")
D: 440 mm (17")
H: 550 mm (22")

SAFETY, STANDARDS, HYGIENE

In accordance with the following regulations:

- Machinery directive 2006/42/EC
- Electromagnetic compatibility 2004/108/EC
- "Low voltage" directive 2006/95/EC
- Regulation 1935/2004/EC (contact with food)
- RoHS directive 2002/95/EC

Harmonized European standards:

- EN ISO 12100-1 and 2:2004 ; NF EN 60204-1: 2006
- EN 60335 -2-64:2004 Commercial electric kitchen machines
- CE (Europe), NFS (USA), UL (USA) and cUL (Canada), KC (Korea)
- GS (Germany) checked by the LNE (National Test Laboratory)

Electrical safety

- On/Off interlock switch in waterproof
- All mechanical parts are ground connected
- All equipment is 100% tested at the end of assembly (special electrical testing bay)

Thermal safety

Motor protected by internal thermal detector.

Acoustic safety

The asynchronous motor is particularly silent.

Hygiene

All removable parts can be put in a dishwasher or easily cleaned with hot soapy water.

PRODUCT: 2-YEAR WARRANTY | MOTOR: 5-YEAR WARRANTY



LEVER JUICER EVOLUTION #70

www.santos.fr

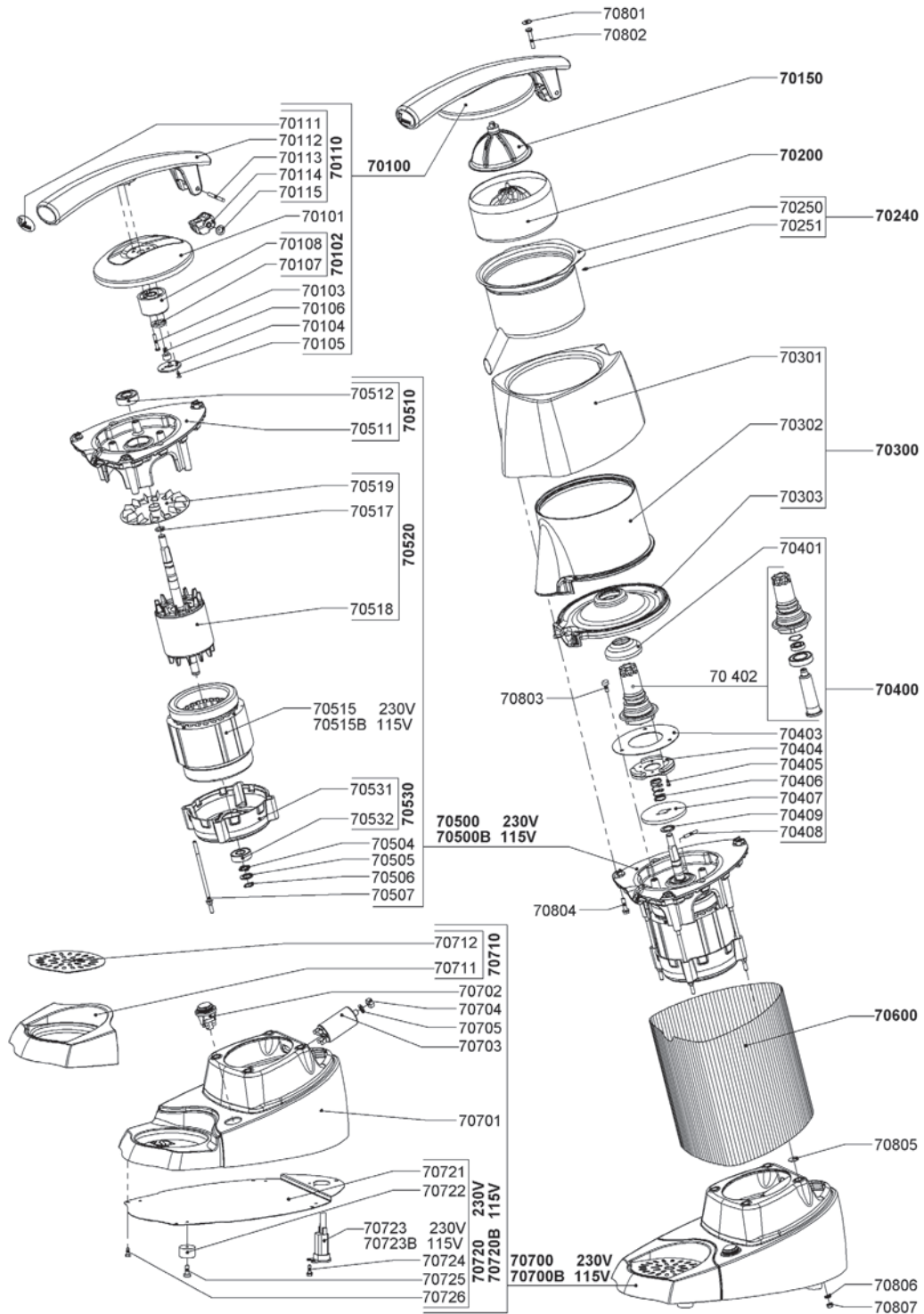

SANTOS

140-150 avenue Roger Salengro – 69120 – Vaulx-en-Velin (Lyon) – FRANCE – Tel. +33 472 37 35 29 – Fax +33 478 26 58 21

Website: www.santos.fr – Email: santos@santos.fr